

Quick Start Up Procedure (Journey Non-Magnetic)

107194 Rev.

B

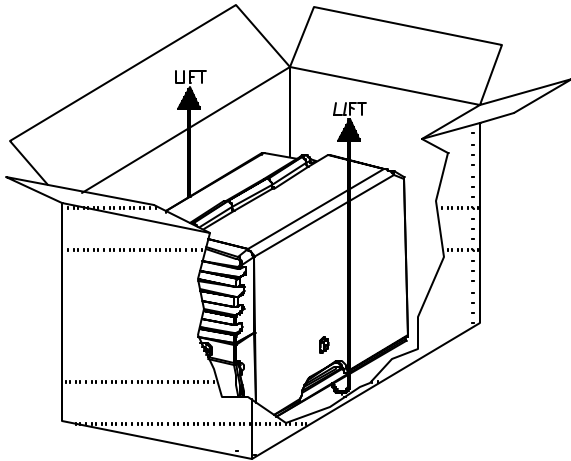

NOTE: Please read the entire Quick Start Up Procedure before beginning installation. For more detailed instructions, please refer to the Journey Quick Reference Guide.

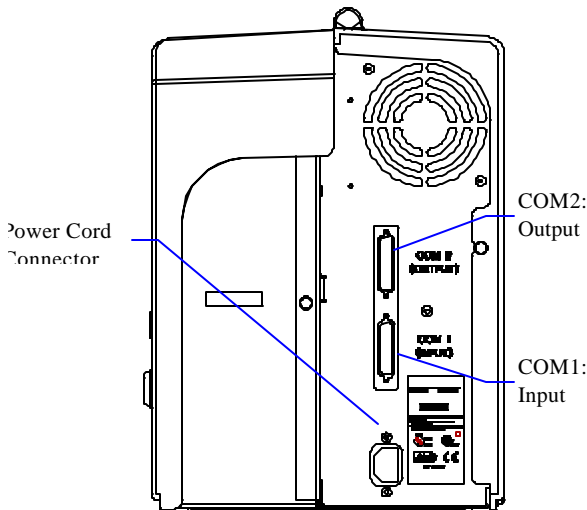

1. Unpack the printer using adequate assistance. Save packing materials.
2. Choose a location for the printer with the following considerations:
 - A level surface capable of adequately supporting printer weight.
 - Near a grounded power receptacle.
 - Adequate clearance: Left side 3 inches (8 cm), Right side 11 inches (28 cm), Top 15 inches (38 cm), Back 1 inch (2 cm).
 - Away from excessive illumination, high and low temperature and humidity, dirt and dust.
3. Align the front base of the printer with the desktop edge to allow the **Output Bin Door** to fully open and hang down out of the way. If the optional print stand is used, align the printer feet with the indentations on the top of the printer stand.

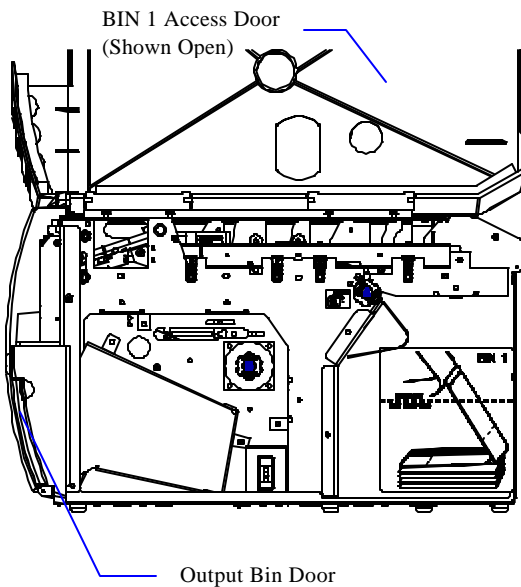

4. Connect and secure the host RS-232 serial connector to the printer **COM1: Input** serial port located on the back of the printer (the bottom connector).
5. Connect a grounded AC power cord to the AC wall receptacle and the printer's AC **Power Cord Connector** located on the back of the printer.
6. Using one of the keys provided unlock the **BIN 1 Access Door** located on the right side of the printer.
7. Open the door fully until it rests on the left top side of the printer (as shown in the illustration).

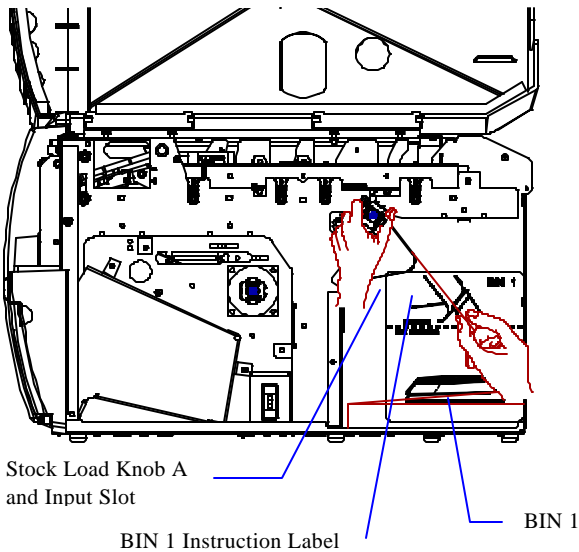

8. Open a box of approved ATB coupon stock so that the staple tab is the leading edge. Remove 500 coupons from the box (1/2 box). Place this stock in **BIN 1** as shown on the **BIN 1 Instruction Label**. *A maximum of 500 standard ATB coupons can be placed in this BIN. Do not install coupons above the dotted line. Over-loading may result in ZONE 1 Jam errors.*
9. Gently square the coupon stack against the inside wall. Insert the staple tab in the **Input Slot** (located at the top left corner of the BIN) until it is snug against the input rollers. Ensure the print side of the coupon facing up.
10. Turn the green **Stock Load Knob A** one-quarter (1/4) turn counterclockwise to fully engage the staple tab in the load rollers.

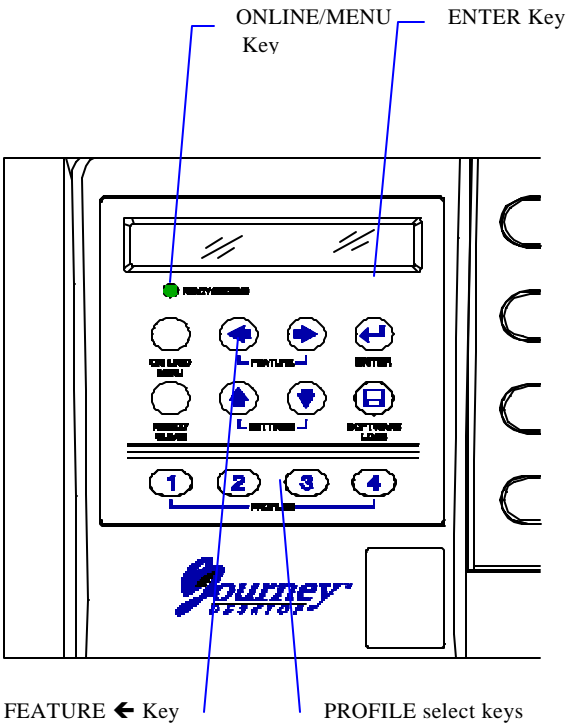

11. Close and lock the **BIN 1 Access Door**.
12. Power the printer on using the AC switch located on the left side near the back. Move the switch to the '1' position (towards the front) to turn on.
13. Wait for the power up self test to complete. The top line of the keypad display should indicate '**On Line:**' when complete.
14. Place the printer Off Line by pressing the **ON LINE/MENU** key.
15. Press the '**FEATURE**' ← (left arrow) key until '**Print 1 Test Coupon**' appears in the keypad display.
16. Press the '**ENTER**' key to print one test coupon.
17. Press the **ON LINE/MENU** to place the printer back On Line.

Refer to the sections **LOADING ATB1 or ATB2 PRINTER SOFTWARE** and **SELECTING PROFILES** for additional instructions.

LOADING ATB1 or ATB2 PRINTER SOFTWARE

- **JOURNEY IS LOADED WITH ATB2 SOFTWARE AS SHIPPED FROM THE FACTORY. NO CHANGES ARE NEEDED IF THIS LOCATION USES ATB2 SOFTWARE.**
- **IF ATB1 SOFTWARE IS REQUIRED AT THIS LOCATION, THE FOLLOWING PROCEDURES MAY BE USED TO LOAD FROM THE PROVIDED DISKETTE.**
- **ENSURE THE CORRECT VERSION (ATB1 OR ATB2) IS LOADED BEFORE PROCEEDING TO THE NEXT SECTION TITLED " *SELECTING PROFILES* "**

Instructions For Loading ATB1 or ATB2 Software

- 1) Locate the diskette for the version of software you will be loading (either Journey ATB1 or Journey ATB2).
- 2) Load this diskette in the disk drive located on the front of the printer.
- 3) Verify the printer is powered on.
- 4) Verify coupons are loaded in **BIN 1**. If not, refer to the previous instructions on loading coupon stock.
- 5) Press the **ON LINE/MENU** key to place the printer Off Line. Verify the top line of the keypad display reads **Off Line:**.
- 6) Press the **SOFTWARE LOAD** key.
- 7) Press the **ENTER** key to start loading the new software.
- 8) As the software is loading, the percent complete (%) symbol will be displayed on the keypad LCD.
- 9) The "Software Load Successful" message will be displayed when finished (2-5 minutes).
- 10) Press the **RESET** key to re-boot the printer.
- 11) Press the **ON LINE/MENU** key to place the printer back On Line.

The format records will need to be loaded for the ATB1 version of software. The PECTAB records will need to be loaded for the ATB2 version of software.

SELECTING PROFILES

Selecting a Profile automatically sets all printer features to preset factory values for the intended application. **Select the correct Profile first** before changing any other features (such as Print Darkness, etc.)

NOTE: Changing the profile is normally only required if the printer is being installed in a Satellite Ticket Printer (STP) application or to restore feature defaults as needed.

Verify the correct version of Journey software (ATB1 or ATB2) is loaded before proceeding. Depending on which version is loaded, refer to the sections below titled ATB1 PRINTER SOFTWARE VERSION or ATB2 PRINTER SOFTWARE VERSION for a description of the available profiles.

CHANGING PROFILES USING THE PRINTER KEYPAD

1. Press the **ON LINE/MENU** key to place the printer Off Line.
2. Press the **PROFILE 1, 2, 3 or 4** key depending on the intended application (as listed below).
3. Press the **ENTER** key to activate and save the correct profile.
4. Press the **ON LINE/MENU** key to place the printer On Line.

ATB1 PRINTER SOFTWARE VERSION

PROFILE NAME ON KEYPAD LCD

1-IWS Intelligent Format

2-

3-STP Intelligent Format

4-

DESCRIPTION

For use with a workstation in a typical agency installation.

(Not Used)

For use with a modem in Satellite Ticket Printing (STP) applications.

(Not Used)

ATB2 PRINTER SOFTWARE VERSION

PROFILE NAME ON KEYPAD LCD

1-ATB2 IWS w/o SCN

2-ATB2 IWS w/ SCN

3-ATB2 STP w/o SCN

4-ATB2 STP w/ SCN

DESCRIPTION

For use with a workstation in a typical agency installation.

(Not used on the Non-Magnetic version of Journey)

For use with a modem in Satellite Ticket Printing (STP) applications.

(Not used on the Non-Magnetic version of Journey)