

POWER SUPPLY SERVICE KIT INSTRUCTIONS (For the DS 180/220 product line)

Part No. BBF-105770 Rev. *

I. POWER SUPPLY MODULE REMOVAL

1) Remove the four #8 screws that fasten the power supply module to the mechanical frame. Disconnect all of the cable connections from the printed circuit board and remove the power supply module from the mechanical frame.

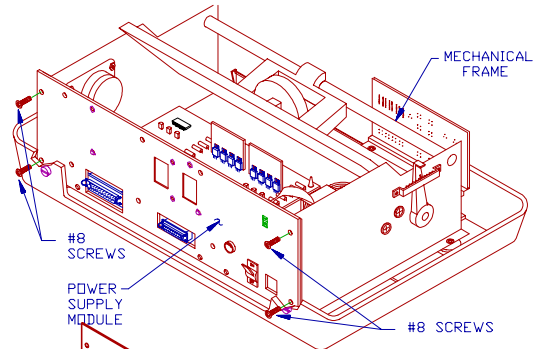

II. REMOVAL OF POWER SUPPLY MODULE COMPONENTS

1) Remove the #6 grounding screw from the printer controller board and lift the controller board from the standoffs.

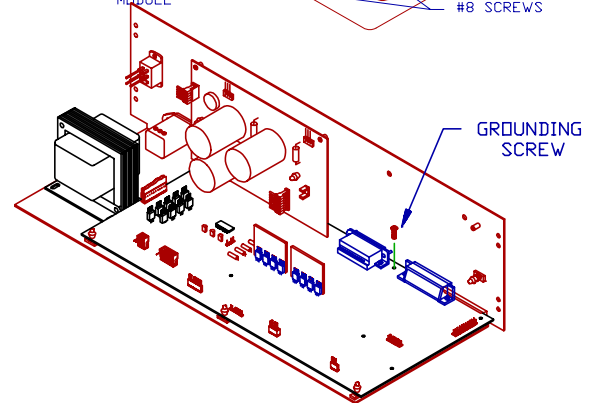

2) Remove the two #6 screws from the power supply PCB. Disconnect the electrical connections from the power supply PCB and remove the circuit board from the supports.

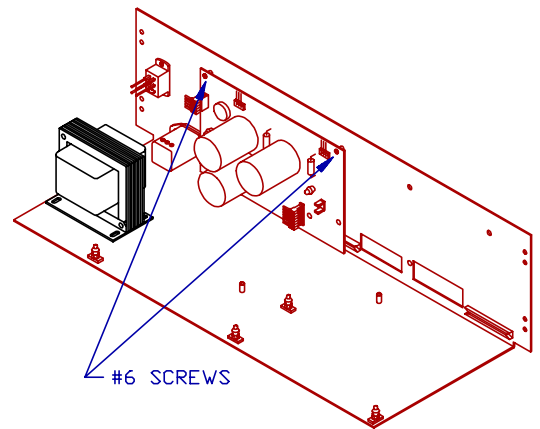

3) Remove the four #8 screws that fasten the transformer to the module chassis and remove the transformer. Cut all wires from the line filter, power switch and voltage switch.

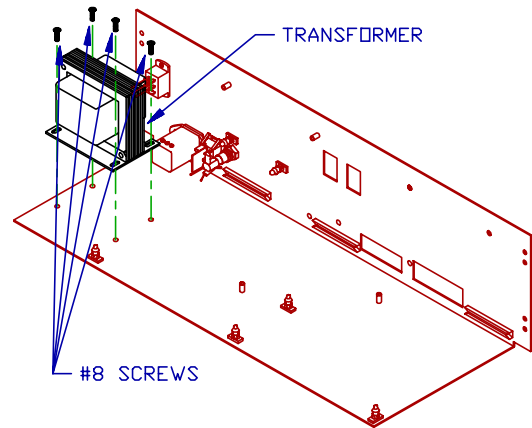

4) Remove the wires connected to the fuse holder. If these wires are soldered it will be necessary to cut them with wire cutters. Remove the retaining nut from the fuse holder and remove the fuse holder from the power supply module chassis.

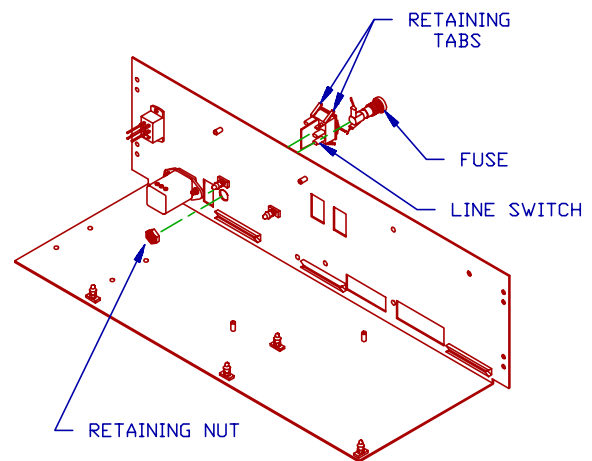

5) Remove the line switch from the module chassis by cutting the retaining tabs.

6) Remove the two #8 screws and keps nuts that fasten the line filter to the module chassis and disconnect the ground screw. Remove the filter.

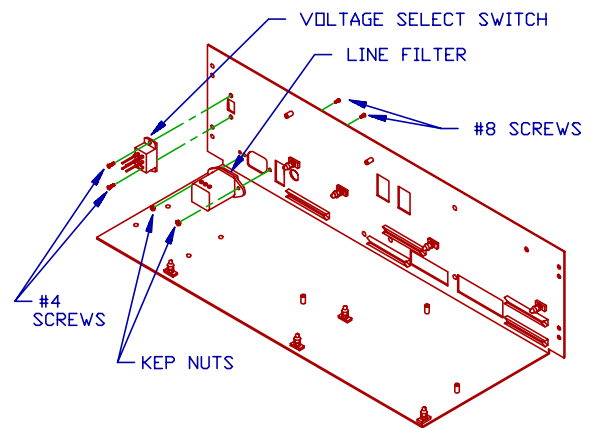

7) Remove the two #4 screws that fasten the voltage select switch to the module chassis and remove the switch.

III. INSTALLATION OF POWER SUPPLY KIT

1) Fasten the voltage select switch to the module using the same hardware removed from the other switch. Make sure the voltage setting is the same as the setting of the voltage switch removed.

2) Fasten the line filter to the chassis using the same hardware removed from the other filter.

3) From the two switches enclosed in the kit, select the one that fits the cutout in your module chassis. If installing the narrow single pole single throw switch, snap the switch into the module making sure the "ON" position is oriented such that when the switch is up, the printer will be on. If installing the wide double pole single throw switch, be sure to snap the switch into the module such that the fast-on connection tabs are oriented as shown.

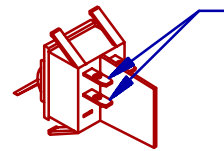

FAST-ON
CONNECTION
LOCATIONS

4) Install the rear mount fuse holder from the inside of the module and secure the retaining nut. Tighten the nut to 15 inch-ounces not to exceed 20 inch-ounces.

5) Attach the loose wire from the transformer to the bottom tab of the switch and the loose wire from the fuse holder to the top tab of the switch. If the wide double pole single throw switch is used, connect the wires to the left most tabs.

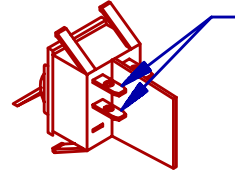

CONNECTION
LOCATIONS

6) Connect the ground wire located on the line filter to the chassis.

7) Mount the transformer to the chassis with the same screws removed from the discarded

transformer.

8) The printer must have the correct fuse installed for the designated voltage setting.

<u>Unit Type</u>	<u>Use Fuse Type</u>
115 Volts	250 Volt 1.5 Amp
230 Volts	250 Volt 0.8 Amp

IV. REASSEMBLY OF PRINTER

1) Replace the power supply PCB in the reverse order of removal.

2) Replace the controller PCB in the reverse order of removal.

3) Reconnect the electrical connections to the power supply PCB and the controller PCB.

4) Fasten the power supply module to the mechanical frame in the reverse order of removal.

5) Install the reassembled mechanism into the base using the same screws that were removed.